



PREVOST.
THE ULTIMATE EXPERIENCE

TPMS & ABS

Function, Safety Features and Advantages

Robert Hitt

Agenda



- Tire Pressure Monitoring System
- Prevost ABS / ESP / ACB

Increased Tire Life with correct Pressure

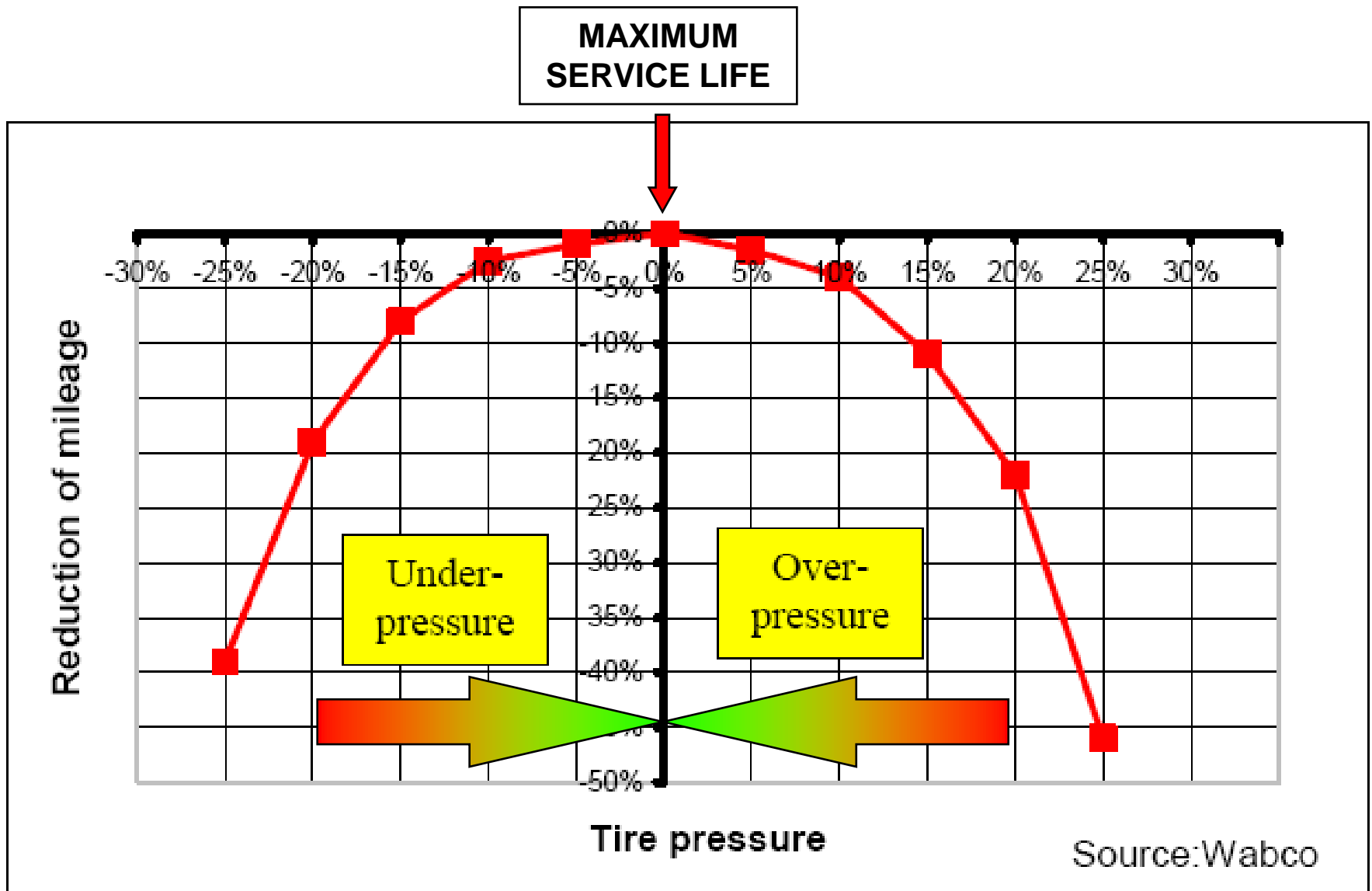

Better Fuel economy with the right tire Pressure

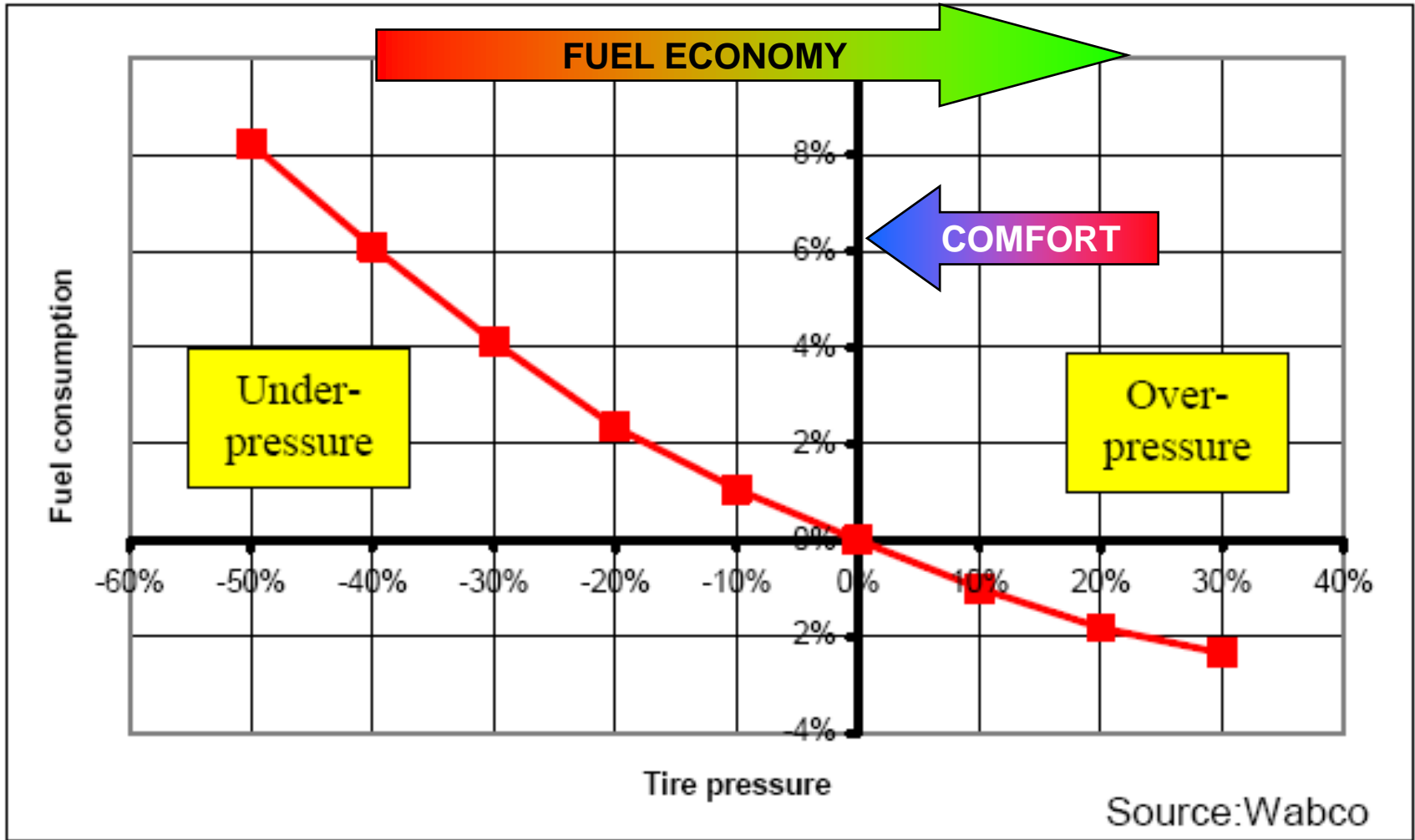

BERU TPMS

BERU system does not include a display. We had to develop one



Display



- All service routines and diagnostics can be performed through the display



LEARN WHEEL ID

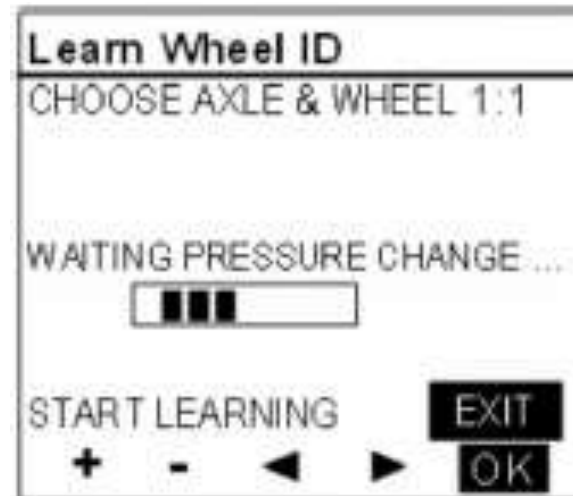
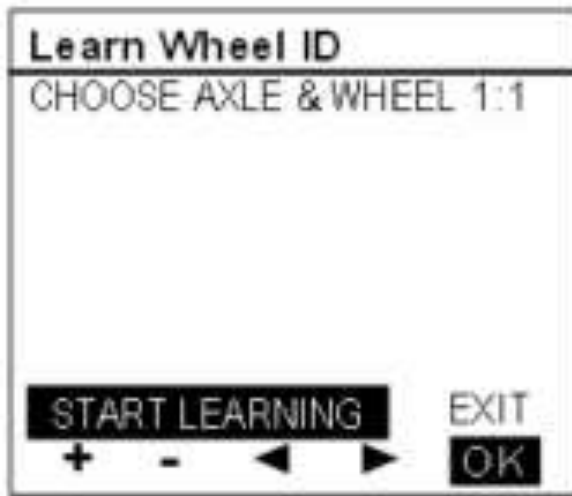
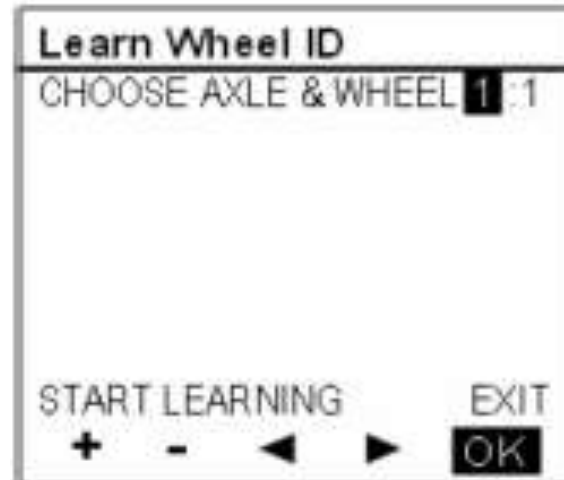

SET TARGET PRESSURES

SETTINGS MENU	
SET WHEEL ID	
LEARN WHEEL ID	
SET TARGET PRESSURES	
ALARM SETTINGS	
DISPLAY SETTINGS	
EXIT	
▲ ▼	OK

SET TARGET PRESSURES	
ENTER AXLE NUMBER: 1	
OLD VALUE: 100 PSI	
NEW VALUE: 100 PSI	
ACCEPT	EXIT
+ - ◀ ▶	OK

ALARM SETTINGS

SETTINGS MENU

SET WHEEL ID
LEARN WHEEL ID
SET TARGET PRESSURES
ALARM SETTINGS
DISPLAY SETTINGS
EXIT

▲ ▼ **OK**

ALARM SETTINGS

PRESSURE
TEMPERATURE
SOUND
EXIT

▲ ▼ **OK**

PRESSURE ALARM

DEVIATION FROM TARGET

OLD VALUE: 10 PSI
NEW VALUE: **11** PSI

ACCEPT EXIT

+ - ◀ ▶ **OK**

TEMPERATURE ALARM

OLD VALUE: 175 °F
NEW VALUE: **180** °F

ACCEPT EXIT

+ - ◀ ▶ **OK**

ALARM SOUND

ON
OFF

▲ ▼ **OK**

OVERALL EXPERIENCE

- BERU system in severe service since 2006
 - Reliable operation readings always available
 - No false alarm
 - Intuitive for the drivers, can operate it without training
 - Tech can program without special tools
 - Receive warnings for high temperature due to brake drag
 - Display characters and menu is easy to read
 - One glance for pre-trip
 - We are able to install BERU to an existing coach

Bendix ABS / ESP / ACB



COMPONENTS OF THE SYSTEM.

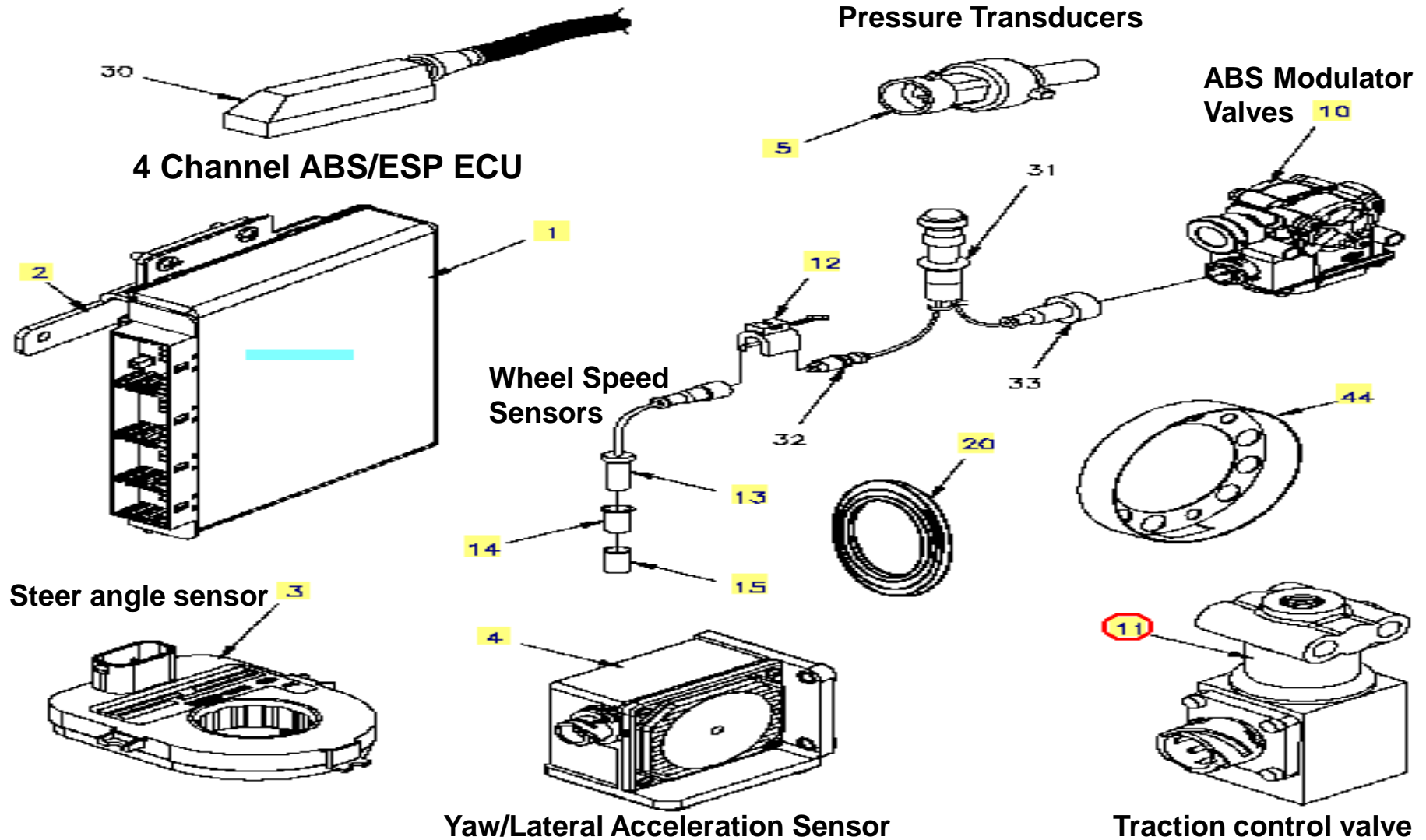

COMPONENTS OF THE SYSTEM.

- Radar transmitter.

Adaptive Cruise Control Radar

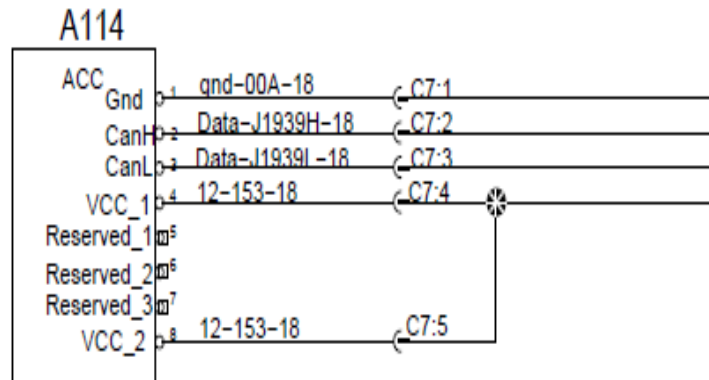

Part Number 563636

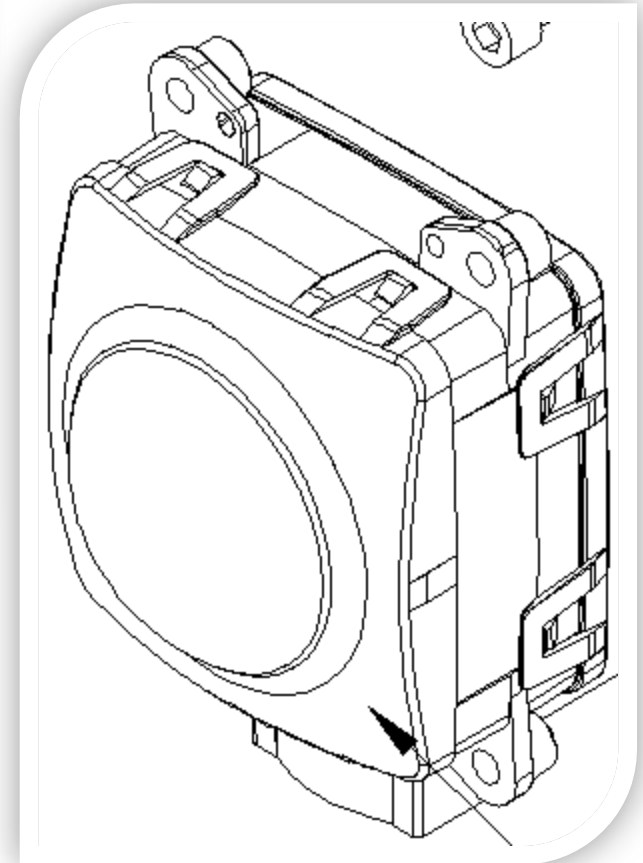



Bendix ACom Diagnostic Software



A close-up, low-angle shot of the front of a dark-colored vehicle, likely a truck or heavy-duty car. The hood features the name 'PREVOST' in a stylized, metallic font. The headlights are prominent on the right side, and the overall lighting is dramatic, highlighting the car's contours against a dark background.

**THE ULTIMATE
EXPERIENCE**

PREVOST.